



# YYM2332S

4-Chanel, 1A, 6V, DC/DC Regulator

---

## DESCRIPTION

The YYM2332S is a highly integrated 4-channel DC / DC regulator using SiP technology. the chip is a monolithic buck switching regulator based on constant on-time (COT) control for fast transient response. Operating with an input range of 2.7V-6.0V, the YYM2332S delivers 1A of continuous output current with integrated P-Channel and N-Channel MOSFETs.

The internal synchronous power switches provide high efficiency. At light loads, the regulator operate in low frequency to maintain high efficiency and low output ripples.

The YYM2332S guarantees robustness with hiccup output short-circuit protection, FB short-circuit protection, start-up current run-away protection, input under voltage lockout and hot-plug in, and thermal protection.

The YYM2332S uses an LGA package, size 8.5x8.5mm, provides a compact solution with zero external components, minimize PCB footprint and reduce product solution costs.

## FEATURES

- 2.7V to 6.0V operating input range
- Up to 1A output current
- Up to 92% peak efficiency
- Internal soft-start
- 1.5MHz switching frequency
- Input under voltage lockout
- Hot-plug in protection
- Short circuit protection
- LGA package

## APPLICATIONS

- 5V or 3.3V Point of Load Conversion
- Set Top Boxes
- Telecom/Networking Systems

- Storage Equipment
- GPU/DDR Power Supply

**TYPICAL APPLICATION**

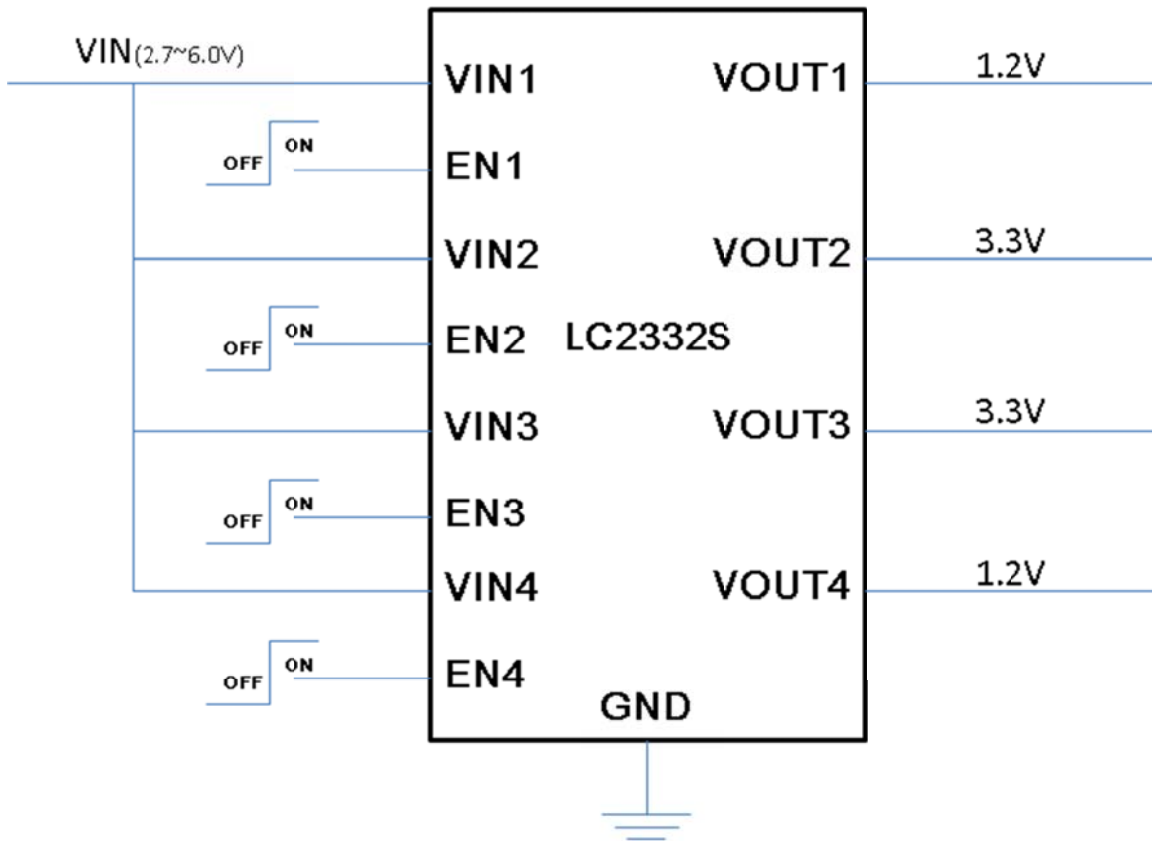

**PIN CONFIGURATION**

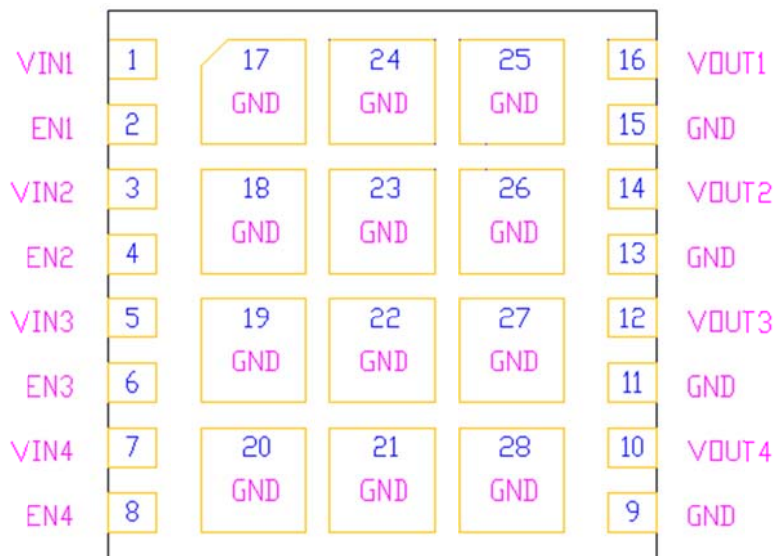

TOP VIEW

**RECOMMENDED OPERATING CONDITIONS**

EN Pins.....-0.3Vto7.0V  
 Vin, Vout Pins.....-0.3V(-1.7V for 20ns) to7.0V(7.1V for 70ns)  
 JunctionTemperature.....150°C  
 Lead Temperature.....260°C  
 Storage Temperature.....-65°Cto +150°C  
 ESD Susceptibility (Human Body Model).....3.5kV  
 Input Voltage VIN.....2.7V to 6.0V  
 Output Voltage Vout.....0.6V to VIN  
 Operating Junction Temperature.....-40°Cto 125°C

**ELECTRICAL CHARACTERISTICS**

<i>VIN=5V, TA=25°C, unless otherwise stated.</i>						
<b>Item</b>	<b>Symbol</b>	<b>Condition</b>	<b>Min.</b>	<b>Typ.</b>	<b>Max.</b>	<b>Units</b>
VIN Under Voltage Lockout Threshold	VIN_UVLO	VIN rising	2.3	2.5	2.7	V
VIN Under Voltage Lockout Hysteresis	VIN_UVLO_HYST	VIN falling		200		mV
VIN Hot-plug in Protection Threshold	VIN_OVP	VIN rising	6.1	6.6		V
VIN Hot-plug in Protection Hysteresis	VIN_OVP_HYST	VIN falling		600		mV
Shutdown Current	ISHDN	VIN=6.0V, VEN=0V		0.1	1	µA
Quiescent Current	IQ	VEN=5V, IOUT=0A, VFB=VREF*105%		40	70	µA
Regulated Feedback Voltage	VFB	2.7V<VIN<6.0V	0.588		0.612	V
PFET On Resistance	RDSON_P	VIN=3.6V, ISW=200mA		260		mΩ
NFET On Resistance	RDSON_N	VIN=3.6V, ISW=-200mA		190		mΩ
PFET Leakage Current	ILEAK_P	VIN=6.0V, VEN=0V, VSW=0V			1	uA
NFET Leakage Current	ILEAK_N	VIN=6.0V, VEN=0V, VSW=6.0V			1	uA
PFET Current Limit	ILIM_TOP		1.6	2	2.4	A
NFET Current Limit	ILIM_BOT		1.2	1.5	1.8	A

Switch Frequency	FSW	IOUT=1A		1.5		MHz
Minimum On Time	TON_MIN			100		ns
Maximum Duty Cycle	DMAX			100		%
EN Input Logic High Voltage	VEN_H	VEN rising, FB=0.3V	1.5			V
EN Input Logic Low Voltage	VEN_L	VEN falling, FB=0.3V			0.4	V
Thermal Shutdown Threshold	TSHDN			150		°C
Thermal Shutdown Hysteresis	THYST			20		°C

**PIN DESCRIPTION**

Pin	Name	Description
2,4,6,8	EN1~EN4	Drive EN pin high to turn on the regulator and low to turn off the regulator.
10,12,14,16	VOUT1~VOUT4	supplies power to the output.
1,3,5,7	VIN1~VIN4	Input voltage pin. VIN supplies power to the IC, Connect a 2.7V to 6.0V supply.
9,11,13,15,17~28	GND	Ground pin.

**BLOCK DIAGRAM**

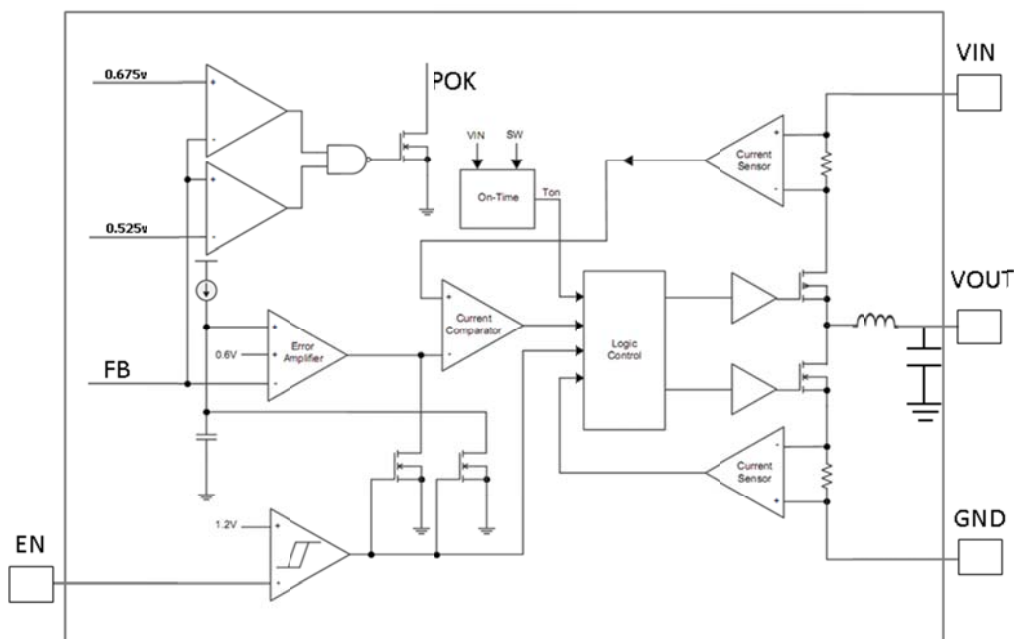

**TYPICAL PERFORMANCE CHARACTERISTICS**

Vin =5V, Vout = 1.8V, TA = +25°C, unless otherwise noted

**Steady State Test**

VIN=5V, Vout=1.8V  
Iout=1A

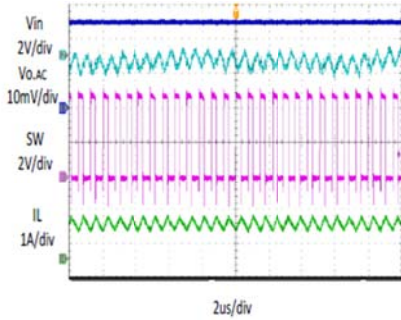

**Startup through Enable**

VIN=5V, Vout=1.8V  
Iout=1A(Resistive load)

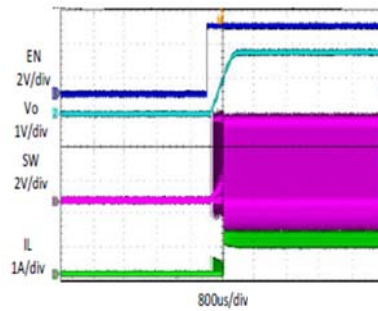

**Shutdown through Enable**

VIN=5V, Vout=1.8V  
Iout=1A (Resistive load)

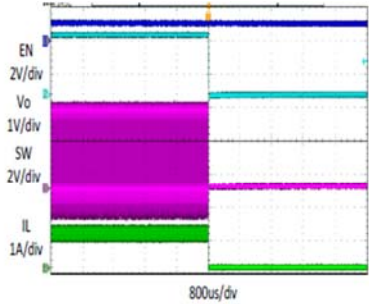

**Heavy Load Operation**

1A LOAD

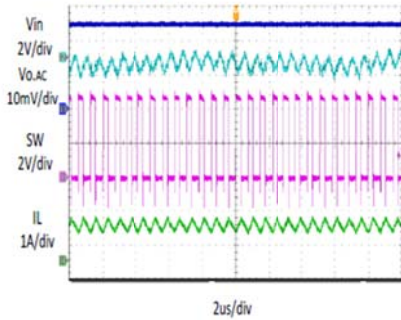

**Medium Load Operation**

0.5A LOAD

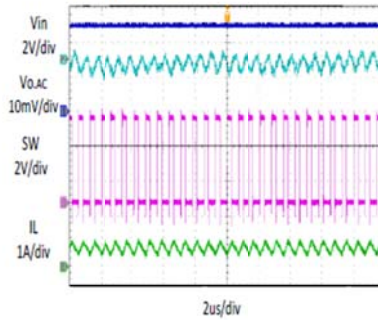

**Light Load Operation**

0 A LOAD

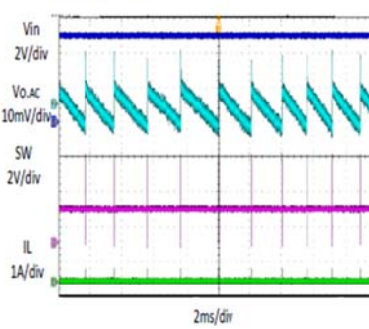

**Short Circuit Protection**

VIN=5V, Vout=1.8V  
Iout=1.0A- Short

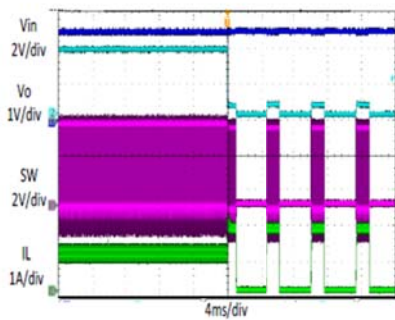

**Short Circuit Protection**

VIN=5V, Vout=1.8V  
Iout= Short-1.0A

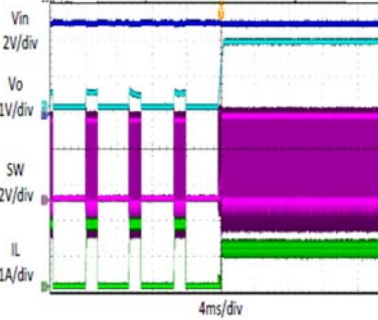

**Load Transient**

LOAD: 0.1A → 1.0A → 0.1A  
2.5A/us, C<sub>T</sub>=1nF

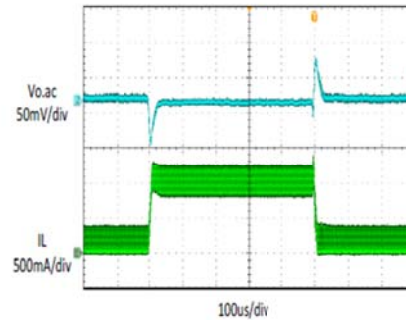

**TYPICAL PERFORMANCE CHARACTERISTICS(continued)**

$V_{in} = 5V$ ,  $V_{out} = 1.8V$ ,  $T_A = +25^{\circ}C$ , unless otherwise noted

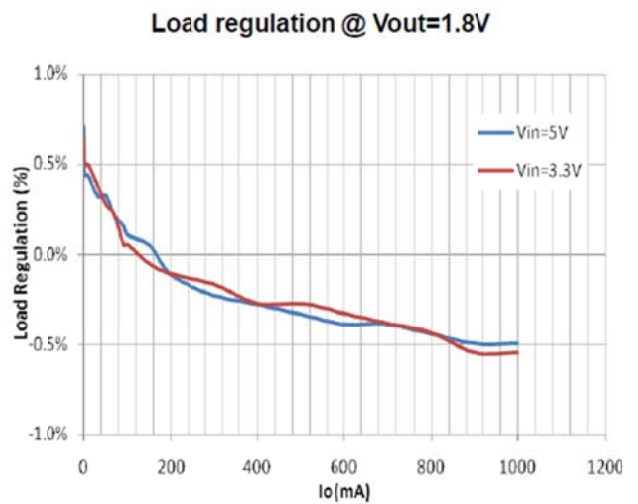
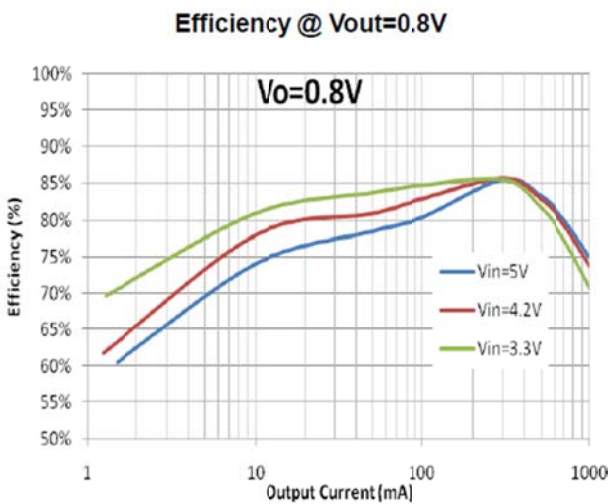
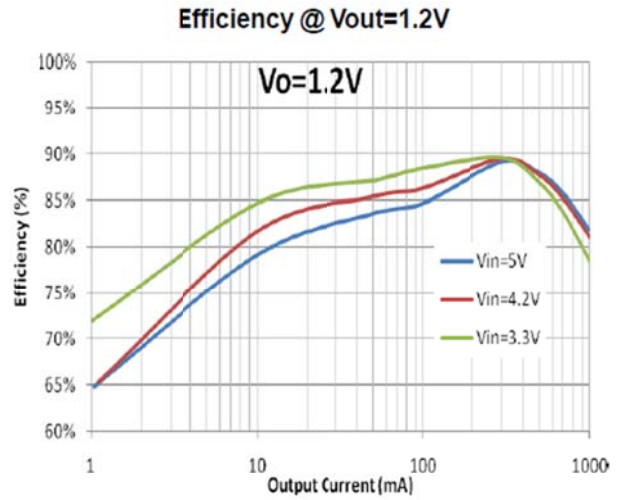
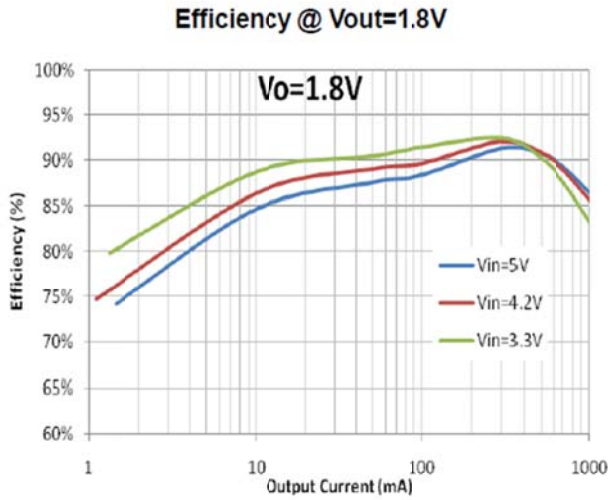

**Quiescent Current Vs. Input Voltage**  
 $V_{IN}=2.7V \sim 6V$ ,  $V_{EN}=2.5V$ ,  $V_{FB}=0.8V$

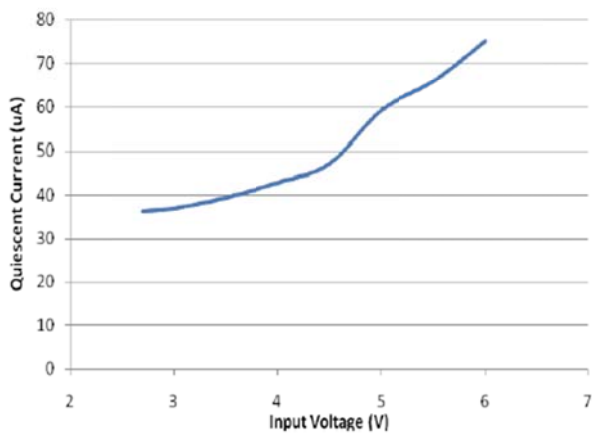

**Shutdown Current Vs. Input Voltage**  
 $V_{IN}=2.7V \sim 6V$ ,  $V_{EN}=0V$ ,  $V_{FB}=0.5V$

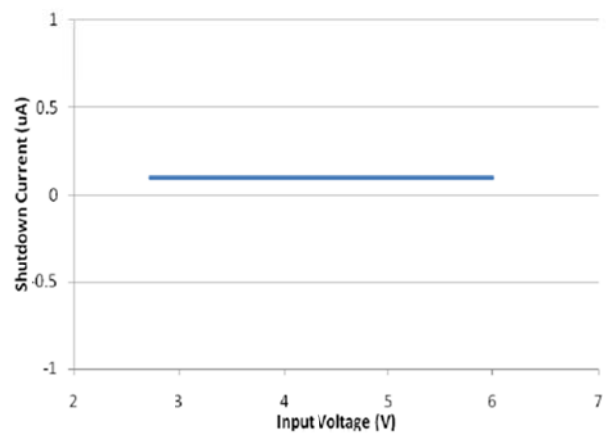

## FUNCTIONAL DESCRIPTION

The YYM2332S is a 4-channel and constant on-time control, synchronous, step-down regulator. It regulates input voltages from 2.7V~6.0V down to an output voltage as low as 0.6V, and is capable of supplying up to 1A of load current.

### Constant On -time Control

The YYM2332S utilizes constant on-time control to regulate the output voltage. The output voltage is measured and the error is amplified by the internal transconductance error amplifier.

Output of the internal error amplifier is compared with the switch current measured internally to control the output current limit.

### PFM Mode

The YYM2332S operates in PFM mode at light load. In PFM mode, switch frequency is continuously controlled in proportion to the load current, i.e. switch frequency decreases when load current drops to boost power efficiency at light load by reducing switch-loss, while switch frequency increases when load current rises, minimizing output voltage ripples.

### Shut -Down Mode

The YYM2332S operates in shut-down mode when voltage at EN pin is driven below 0.4V. In shut-down mode, the entire regulator is off and the supply current consumed by the YYM2332S drops below 4 $\mu$ A.

### Power Switches

P-channel and N-channel MOSFET switches are integrated on the YYM2332S to down convert the input voltage to the regulated output voltage.

### Short Circuit Protection

When output is shorted to ground, the switching frequency is reduced to prevent the inductor current from increasing beyond PFET current limit. If short circuit condition holds for more than 1024 cycles, both PFET and NFET are forced off and can be enabled again after 8ms. This procedure is repeated as long as short circuit condition is not removed.

### Hot Plug-in Protection

When input voltage is greater than hot plug-in protection threshold, typical 6.8V, it will disable YYM2332S. When input voltage decrease below 6.4V, it will be enabled again.

### Thermal Protection

When the temperature of the YYM2332S rises above 150°C, it is forced into thermal shut-down. Only when core temperature drops below 130°C can the regulator becomes active again.

### PACKAGE OUTLINE

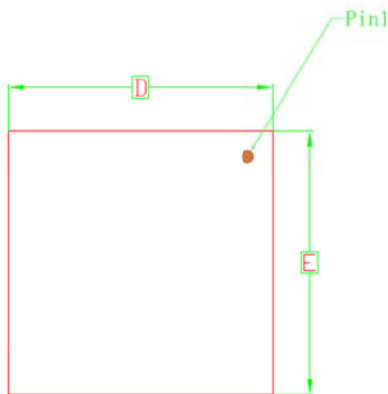

Top View

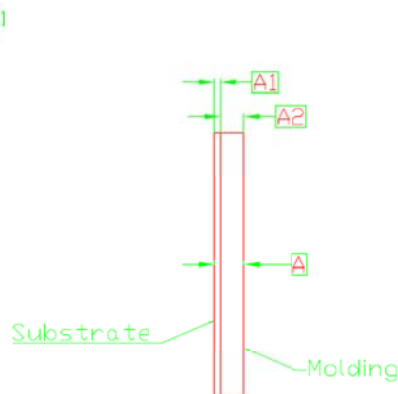

Side View

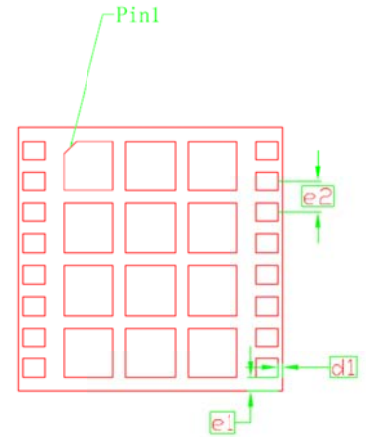

Bottom View

Dimensional References					Unit: mm
Symbol	Dim.	Tol.	Symbol	Dim.	Tol.
A	0.930	±0.100	D	8.500	±0.100
A1	0.180	±0.030	E	8.500	±0.100
A2	0.750	±0.05	d1	0.150	±0.05
e2	1.00	±0.05	e1	0.450	±0.05